



FÜLLSTANDSMELDER

MN21

Produktlinie: Druck

Füllstandssensor, der durch den vom Material auf die Membrane ausgeübten Druck aktiviert wird. Robuste Konstruktion mit Aluminiumgehäuse.



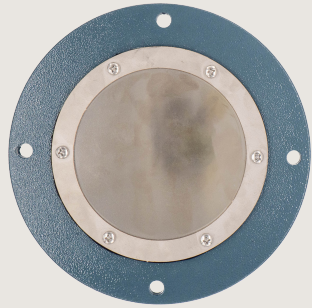

Feststoffe Lebensmittel



VORTEILE

- Ein **EINFACH ZU INSTALLIERENDES** Gerät, für dessen Montage keine Kalibrierung, Wartung oder speziellen Werkzeuge erforderlich sind.
- **ANPASSUNGSFÄHIG** an jedes Material, dank der einstellbaren Empfindlichkeit.
- Äußerst **VIELSEITIG** kann es vertikal, horizontal oder schräg montiert werden.

 IECEx - ATEX
STAUB ZONE 20/21

 Konformität der
Europäischen Union

 Konformität für
Vereinigtes Königreichs

VERFÜGBARE VERSIONEN

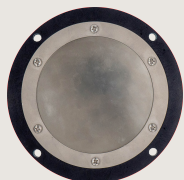

MN21F

Version mit kleinerem Flansch

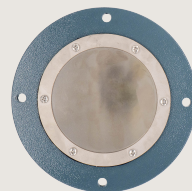

MN21T

Version zur Überdruckregelung



FÜLLSTANDSMELDER MN21



Feststoffe Lebensmittel

Produktlinie: **Druck**

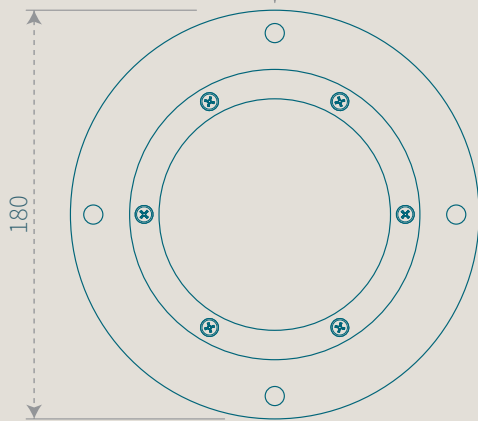
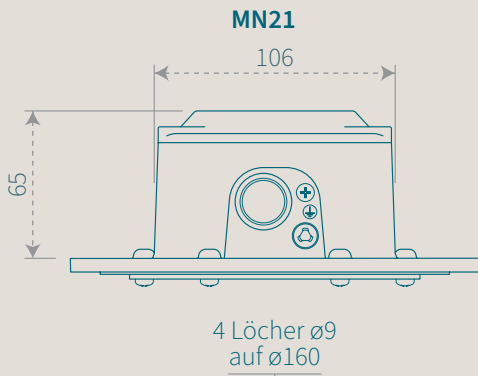

Personalisierungen



Faston-
Anschlüsse
(standard)

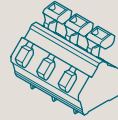

Federklemmen



Runder
Stecker
M12



Lampe

